



accutherm

INTERNATIONAL

ABN 17 100 208 964

EDUCATION DEPARTMENT ACCU-TEST

GAS SAFETY SHUT OFF SYSTEM

Operating & Installation Manual



Head Office (Melbourne)

18 Pickering Road
Mulgrave VIC 3170
T: +61 3 9763 6335
F: +61 3 9763 8003
sales@accutherm.com.au

Sydney

7/4 Abbott Road
Seven Hills NSW 2147
T: +61 2 9620 4123
F: +61 2 9624 2666
www.accutherm.com.au

Brisbane (Distributor)

17 Medway Street
Rocklea QLD 4106
T: +61 7 3255 9255
F: +61 7 3255 9655



Quality
ISO 9001

Index

1. PRINCIPLE OF OPERATION	3
2. INSTALLATION INSTRUCTIONS	5
2(a) – Gas Train Components	5
2(b) – Master/Room Control Panel Front Description	7
2(c) – Master/Room Control Panel Inside Description	8
3. STEPS FOR INITIAL SETUP & TESTING OF OPERATION	9
4. FAULT SIMULATION TESTS.....	11
Test 1 – External Interlocks	11
Test 2 – Gas Leak Check	12
Test 3 – Loss Of Power	13
Test 4 – Full Flow Test	14
5. NORMAL OPERATING INSTRUCTIONS	15

1. PRINCIPLE OF OPERATION

The Gas Safety Shut-off system (ACCU-TEST) is purposely designed to prevent gas being restored to open, unsafe downstream piping, appliances and outlets. The safety of personnel and plant is given added protection with the installation of the ACCU-TEST system.

There are two parts to the Education Department ACCU-TEST systems, a MASTER SYSTEM, to be installed in the main gas supply, and a ROOM SYSTEM, to be installed in the gas supply to each room.

The gas supply can be interrupted either by manual activation or automatically. The MASTER SYSTEM is fitted with a 24 hour 7 day timer, for programming during commissioning, to set the time period each day that the main gas supply is available to be switched on and the time that the main gas supply is switched off. Each ROOM SYSTEM is supplied with a gas detector to be installed in the room that will shut off the gas supply if the gas detector senses gas in the room. It is also possible to safely shut off the gas flow by connecting remote interlocks (such as Emergency Stop "E-Stop" buttons, fire alarms or such like inputs) into the control circuit.

Linking to remote activation devices will ensure the safe isolation of gas flow making it ideal for appliances in residential and commercial kitchens, schools, TAFE colleges, hospitals, hotels, apartment buildings etc. The ACCU-TEST is an ideal solution for the protection of appliances that do not have inbuilt safety shut-off controls.

The ACCU-TEST system will also cut the gas flow to downstream pipe work in the event of a power failure. Once power is restored the system will need to be re-set - this requires all gas outlets downstream to be closed before the system will allow gas to be safely delivered.

The valve assembly is supplied with an adjustable limiting orifice valve and gas pressure switch that will both require setting after installation and during commissioning.

Once the system has been tripped, restoration of gas is only possible by following the resetting procedure.



SAFETY ALERT

The ACCU-TEST prevents gas being restored to the downstream piping. It does not detect unsafe conditions once gas has been restored to the installation.

To establish that the downstream piping is gas tight, the fitted pressure switch and the limiting orifice valve (LOV) must be adjusted during the commissioning of the system to meet the installed site conditions. The units therefore cannot be preset, and must be adjusted by the person commissioning it. The system also has another safety feature: if it detects a catastrophic rupture or major leak in the downstream piping, it will shut off the gas supply. Such a rupture or leak would cause the downstream pressure to fall below the set point of the pressure switch (usually at 50% of inlet pressure). This would activate the switch, and therefore shut the main gas solenoid, cutting off the gas supply.



SAFETY ALERT

Installation and commissioning of the ACCU-TEST must only be performed by competent and suitably licensed Gas Fitters and Electricians. Compliance to all regulations and guidelines must apply. Refer to your local authorities or governing bodies for further information.

The correct and proper installation and commissioning of the ACCU-TEST is critical. If the system is not installed properly, and if the limiting orifice valve and pressure switch are not adjusted correctly, it could be possible to restore gas to unsafe conditions.

For Example:

Leaving a Bunsen burner on in a school science room will normally result in a small amount of gas being discharged. Over a period of time however, this can build up into an explosive and catastrophic situation.

In this example, the limiting orifice valve needs to be adjusted to guarantee that less gas passes through it than what would pass through the Bunsen burner. Correct adjustment will prevent the downstream gas pressure from increasing thereby stopping the pressure switch from activating and will not allow the main gas to be restored.



SAFETY ALERT

It is important to note that ACCU-TEST may allow gas to flow in the event of ruptured leaking piping or an appliance that has been inadvertently left on, when the gas flow is lower than the maximum flow capacity of the main valve. See installation instructions.

2. INSTALLATION INSTRUCTIONS

The following instructions provide information required to set up, functionally test and use the ACCU-TEST system. For any assistance please contact the supplier for more information.



SAFETY ALERT

Do not attempt to install or operate the ACCU-TEST system unless you have fully read and understood the instructions.

2(a) – Gas Train Components

The ACCU-TEST gas train consists of the following components:

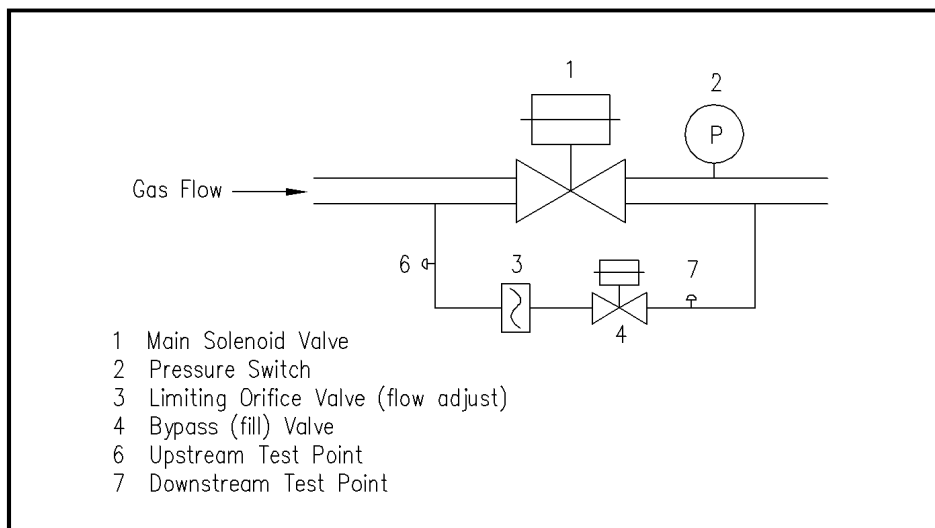

Figure 1 – Gas Train Components

Note: The components shown may be in a different position on some models.



SAFETY ALERT

Installation and commissioning of the ACCU-TEST must only be performed by competent and suitably licensed Gas Fitters and Electricians. Compliance to all regulations and guidelines must apply. Refer to your local authorities or governing bodies for further information.

Installation is made simple as the ACCU-TEST is supplied as an assembly and all required parts are included. The ACCU-TEST can be easily plumbed into the gas supply piping. To satisfy varied site installation requirements some interconnecting wiring between the control box and the components will be required. Please refer to the relevant electrical schematic supplied with the ACCU-TEST.



SAFETY ALERT

The ACCU-TEST pressure switch & limiting orifice valve (LOV) are NOT supplied pre-set for the inlet and operating flow & pressures stated but are supplied to cover the range specified at time of order. Adjustments to settings must only be performed by competent and suitably licensed persons.

Important:

- The direction of flow on the gas valves must be observed.
- Gas pressure and electrical supply must be confirmed.
- The voltage of the ACCU-TEST must be checked to confirm the power source.
- Wiring from the control panel to the gas train must comply with local codes.
- The equipment is rated IP54.
- As only a small amount of gas is delivered during the fill leak testing it is recommended that the ACCU-TEST gas train is situated as close as possible to the appliance under supervision. If the downstream pipe-work is too large it will take a very long time to fill the pipe.
- The solenoid valves must be installed so that the coil is horizontal to, or above, the pipe centre line. When installed the valve coils must not be under the body. The pressure switch must not be upside down – i.e. the adjustment dial face must not point downwards.
- Where multiple appliances need to be supervised, it is advisable to have separate ACCU-TEST systems for each area.
- All safety interlocks that are added must be normally closed volt free contacts which will “fail open” when in the fault mode. These interlocks may be emergency stop buttons, sprinkler flow switches, key isolators, smoke detectors etc.



SAFETY ALERT

The operation integrity of any interlock is the responsibility of the installing contractor. Accutherm accepts no responsibility for any remote devices connected.



SAFETY ALERT

Installation and commissioning of the ACCU-TEST must only be performed by competent and suitably licensed Gas Fitters and Electricians. Compliance to all regulations and guidelines must apply. Refer to your local authorities or governing bodies for further information.

Important:

Before gas or electricity is turned on make sure every isolation point is in the “OFF” or closed position. Once the ACCU-TEST has been connected to the gas and electrical services the next step is to commence with the initial set up and operation of ACCU-TEST.

2(b) – Master/Room Control Panel Front Description



Figure 2 – Control Panel Front Description

1. Keyed Power On Switch (spring return)
2. Mains Power On Illumination
3. System Start Pushbutton/System Running Illumination
4. System Stop Pushbutton
5. Emergency Stop Pushbutton

2(c) – Master/Room Control Panel Inside Description

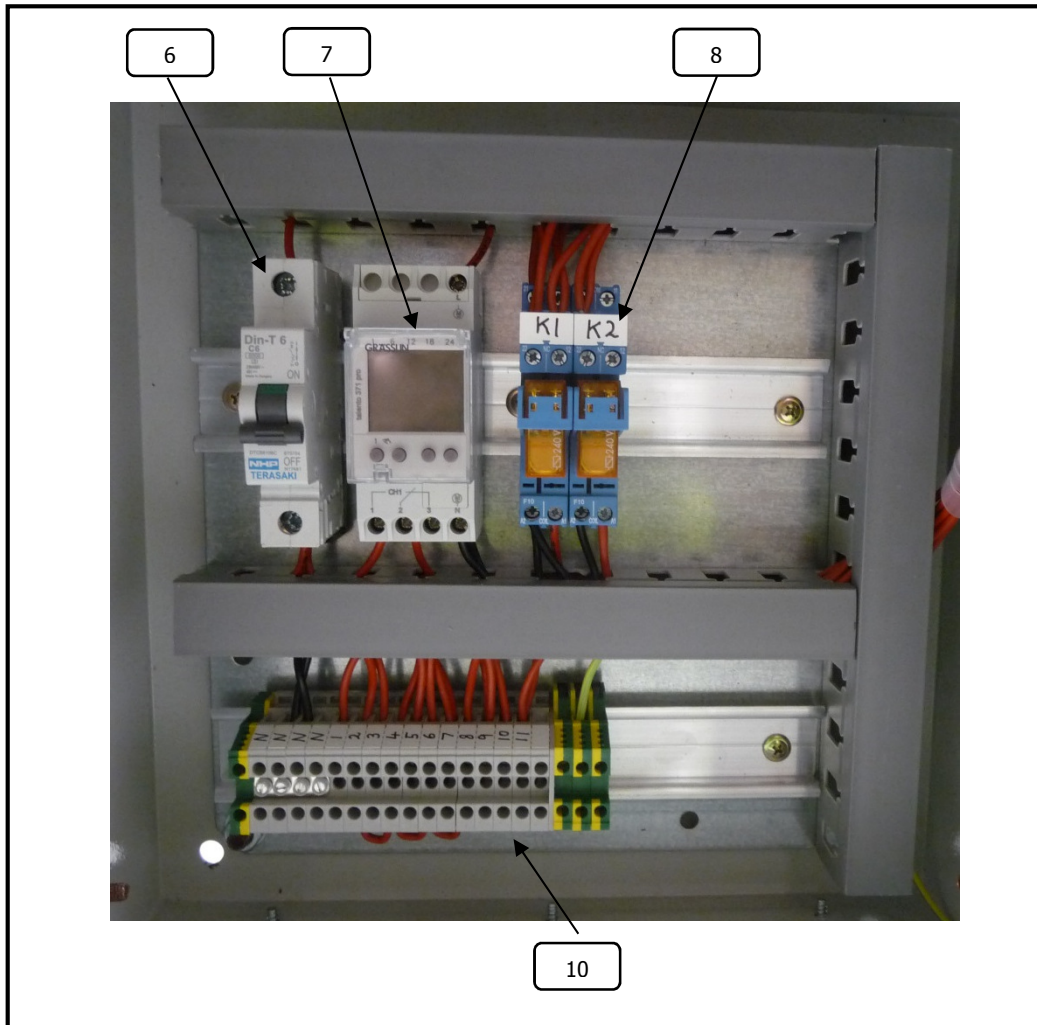

Figure 3 – Control Panel Inside Description

6. Circuit Breaker
7. 24 Hour, 7 Day Programmable Timer – (typically) Master Panel only
8. Relays
9. Terminals

3. STEPS FOR INITIAL SETUP & TESTING OF OPERATION



SAFETY ALERT

For initial setup, you may need to open to atmosphere the downstream piping. Make sure that there is adequate ventilation in the area and there are no naked flames or sources of ignition.

Venting of gas must be in accordance to an approved and safe procedure. Refer to the approved regulations and guidelines applicable to this process.

1. DO NOT turn on any power.
2. Make sure all downstream gas outlets of the ACCU-TEST gas train are shut off.
3. Check inlet gas pressure is within specified and operating limits.
4. Find out the rating/gas requirement of the smallest downstream appliance (eg: Stove Burner, 3MJ/hr).
5. Slowly open upstream gas isolation valve (by others) to permit gas to ACCU-TEST.
6. Check for any upstream gas leaks - if any are present immediately isolate and repair them.
7. Using a manometer, check the upstream inlet gas pressure (refer Fig. 1 position 6), to confirm it is as per the designed operating pressure rating. Record the result.
8. Check the setting of the *Pressure Switch*, (refer Fig. 1 position 2), and adjust the setting to 50% of the inlet pressure.
9. Check again that all downstream gas outlets are safely isolated.
10. Using a manometer, check the downstream gas pressure (refer Fig. 1 position 7). This reading MUST BE zero. If it is more than zero, bleed off the gas remaining in the downstream pipework (see safety alert above regarding ventilation).
11. Leave the manometer connected to the *Downstream Test Point* (refer Fig. 1 position 7).
12. Check that the *Limiting Orifice Valve* (LOV) is fully closed (refer Fig. 1 position 3).
13. Turn keyed power *ON Switch (1)* to turn on power (switch will spring return when released).
14. The *Mains On (2)* indicator should now be illuminated. The *Start/Operation (3)* indicator should not be illuminated.
15. For systems fitted with 24 hour, 7 day *timer (7)*, program the timer by following the timer instruction sheet supplied.
16. If the system is fitted with a timer and it is being commissioned outside of the timers programmed operating times, then the timer will need to be switched to manual mode and turned on to enable commissioning – see timer instruction sheet. Remember to return timer to automatic mode when commissioning has been completed.
17. Open the gas cock of the smallest downstream appliance (see safety alert above regarding ventilation).
18. Push and hold the *Start/Operation Pushbutton (3)* and SLOWLY open the LOV (refer Fig. 1 position 3) to the minimum flow setting. This minimum flow setting MUST BE LESS than the smallest appliance flow connected. This is necessary to ensure the system cannot be restored when an outlet has been left open. Observe the manometer reading and ensure that the

pressure is less than the pressure switch setpoint. If the pressure rises, close the LOV slightly. If the pressure rises ABOVE the pressure switch setpoint, shut down the ACCU-TEST system.

Bleed the gas downstream, restart the system, then follow the procedure again from Step 10.

19. Close all downstream outlets.

20. Press and hold the *Start/Operation Pushbutton (3)* until it is illuminated - this signals that the piping is gas tight. The Main Solenoid Valve (refer Fig. 1 position 1) will be energized.

21. The downstream piping is now charged with gas.

22. Release the *Start/Operation Pushbutton (3)*.

23. The initial set up & testing is now complete. Move to the next section **Fault Simulation Tests**.

4. FAULT SIMULATION TESTS



SAFETY ALERT

Fault simulation tests of the ACCU-TEST must only be performed by competent and suitably licensed Gas Fitters and Electricians. Compliance to all regulations and guidelines must apply. Refer to your local authorities or governing bodies for further information.

TESTS

The ACCU-TEST is designed to prevent the gas supply from being restored until the downstream pipe-work is pressure tight and all gas outlets are turned off.

To prove the correct and proper operation of each ACCU-TEST safety shut off system the following fault simulation tests are necessary:

- TEST 1 – External Interlocks
- TEST 2 – Gas Leak Check
- TEST 3 – Loss Of Power
- TEST 4 – Full Flow Test

NOTE: If the system is fitted with a timer and the tests are being performed outside of the timers programmed operating times, the timer will need to be switched to manual mode and turned on to enable the testing to be performed – see timer instruction sheet. Remember to switch the timer back to automatic mode when the testing has been completed.

Test 1 – External Interlocks

Objectives:

- To ensure that any external interlocks fitted are functioning correctly and that they shut off the gas supply via the ACCU-TEST.

Procedure:

1. Operate all the remote safety interlocks (including remote gas detectors, where fitted) to ensure they shut down the ACCU-TEST.
2. When each interlock is tripped the Main Solenoid Valve (refer Fig. 1 position 1) should shut off and the ACCU-TEST *Mains On (2)* and *Start/Operation (3)* indicators should both be off.



SAFETY ALERT

Warning: All interlocks must be proven. Bridging contacts to simulate operation is dangerous and should be discouraged.

Test 2 – Gas Leak Check

Objectives:

- To prove that the system will NOT RESTORE the main gas supply when gas pressure is lost by the smallest appliance outlet being left open.
- To prove that the LOV (refer Fig. 1 position 3) has been set to below the lowest gas flow outlet connected to the system.



SAFETY ALERT

To simulate the fault you may need to open to atmosphere the downstream piping. Make sure that there is adequate ventilation in the area and there are no naked flames or sources of ignition.

Venting of gas must be in accordance to an approved and safe procedure. Refer to the approved regulations and guidelines applicable to this process.

Procedure:

1. Shutdown the ACCU-TEST system by pressing the *OFF Pushbutton (4)*.
2. Bleed off all gas in the downstream pipe work (see safety alert above).
3. Close off all outlets except for the smallest gas outlet or device.
4. Fit a manometer to the Downstream Test Point (refer Fig. 1 position 7).
5. Turn on the keyed power *ON Switch (1)* and attempt to charge the downstream gas piping by pressing the *Start/Operation Pushbutton (3)*.
6. **SAFETY NOTE: Gas will be escaping from the open pipe or device (see safety alert above)**
7. If the LOV (refer Fig. 1 position 3) has been set correctly the gas piping will not be able to be pressurised.
8. Pressurisation time will depend on the size and length of piping installed.
9. Observe the manometer reading to see if pressure is increasing.
10. If the LOV (refer Fig. 1 position 3) is set correctly the manometer pressure reading should not rise above the Pressure Switch setting (refer Fig. 1 position 2) and the Pressure Switch will not activate (refer Fig. 1 position 2).
11. If the manometer reading continues to increase, the Pressure Switch will activate (refer Fig. 1 position 2). If this occurs, immediately shut the system down.
12. Refer to section: “**Steps for Initial Setup & Testing of Operation**” – Setting the LOV (Start from Step 10).
13. If the gas pressure does not increase past the switch setpoint, the main gas valve will remain closed. Shut the system down by pressing the *OFF Pushbutton (4)*.
14. Close off the opened gas outlet.
15. Remove the test manometer.
16. Reset the system by turning the keyed power *ON Switch (1)* then pushing and holding the *Start/Operation Pushbutton (3)* until it illuminates.



Test 3 – Loss Of Power

Objectives:

- To prove that the system will shut off the main gas solenoid when power is lost and only open the main gas solenoid if the system is gas tight.

Once you have successfully completed step 23 of the **Initial Setup & Testing of Operation** the following steps can be undertaken to prove the correct operation.

Procedure:

1. Connect a manometer to the downstream pressure test point.
2. Turn off the ACCU-TEST by pressing the *Emergency Stop Pushbutton (5)*.
3. The *Main Solenoid Valve* (refer Fig. 1 position 1) will close. Check and record result.
4. Restore power and reset the system if required.
5. Externally isolate the source supply to the control box.
6. The *Main Solenoid Valve* (refer Fig. 1 position 1) will close. Check and record result.
7. Restore power and reset the system if required.

Special Notes:

- 1) In the event of external de-activation or loss of the mains power supply to the control panel, the supply of gas will be shut off. The ACCU-TEST will need to be reset as per the “**Normal Operation**” section instructions unless there has been no loss of gas pressure.
- 2) If power is restored and there has been no loss of downstream gas pressure, the *Mains On (2)* and the *Start/Operation (3)* indicators will be illuminated and the downstream piping will remain charged with gas and will be ready for operation. The Main Solenoid Valve (refer Fig. 1 position 1) will be opened.
- 3) If power is restored and there was a gas leak from damaged pipe-work or gas outlets had been left on, and the pressure in the downstream pipe-work is lower than the ACCU-TEST Pressure Switch setting then the ACCU-TEST Main Solenoid Valve (refer Fig. 1 position 1) will not operate. Locate and repair source of leak then restart as per normal set up.

Test 4 – Full Flow Test

Objectives:

- To ensure the ACCU-TEST and supply pipe are large enough to provide enough gas downstream when ALL appliances are on.



SAFETY ALERT

Appliances must be properly supervised during this test. It is the responsibility of the installer to ensure adequate ventilation and supervision of equipment at all times.

Procedure:

1. Reset the ACCU-TEST.
2. Connect a manometer to the downstream test point (refer Fig. 1 position 7).
3. Monitor the manometer reading while switching on all the appliances downstream, one at a time.
4. The gas pressure should not drop below the Pressure Switch set point.
5. If it does fall below the setpoint, the Pressure Switch will trip, and the gas supply will be cut off.
The pipework or ACCU-TEST may be too small to handle the require flow to all appliances.

REMEMBER – If the *timer (7)* was placed into manual mode for commissioning, return timer to automatic mode when commissioning has been completed.

5. NORMAL OPERATING INSTRUCTIONS

The normal operating instructions for ACCU-TEST system apply once the initial testing, functional operation and fault testing have all been successfully completed.

To start the system

1. Do NOT turn on any power.
2. Make sure all gas outlets downstream of the ACCU-TEST gas train are shut off.
3. Slowly open upstream gas isolation valve (by others) to permit gas to ACCU-TEST.
4. Turn the keyed power *ON Switch (1)*. Switch will spring return when released.
5. The *Mains On (2)* indicator will be illuminated.
6. Press and hold in the *Start/Operation Pushbutton (3)* which will open the Bypass (fill) valve, (refer Fig. 1 item 4).
7. Continue to hold the *Start/Operation Pushbutton (3)* in until it illuminates signaling that the piping is full. The Main Solenoid Valve (refer Fig. 1 item 1) will be energized.
8. The downstream piping is now charged.
9. Release the *Start/Operation Pushbutton (3)*.
10. The system is now ready.

To stop the system

1. Push the *Emergency Stop Pushbutton (5)*
or
2. Press the *Off Pushbutton (4)* or isolate the mains power
or
3. Initiate one of the external interlocks, eg: an Emergency Stop button
or
4. Turn off the Gas Supply

Disclaimer

Accutherm International Pty Ltd continually improves and upgrades its products and reserves the right to alter the design and documentation of this device without notice.

Accutherm International Pty Ltd shall not be liable for damages resulting from misapplication or misuse of its products.

The design and integrity of all interlocks connected to the ACCU-TEST are the responsibility of the installing contractor.