



accutherm

I N T E R N A T I O N A L

ABN 17 100 208 964



GA Series

Diaphragm Gas Meter

Range

The GA series Gas Meters are made of steel external casings which are finished with epoxy resin and polyester powder coating. This series of meters are suitable for accurate measurement of flow mediums of natural gas and LPG. The performance and parameters comply with AS4647- 2011 and the International Standards EN1359 and OIMLR31

Head Office (Melbourne)

18 Pickering Road
Mulgrave VIC 3170
T: +61 3 9763 6335
F: +61 3 9763 8003
sales@accutherm.com.au

Sydney

7/4 Abbott Road
Seven Hills NSW 2147
T: +61 2 9620 4123
F: +61 3 9763 8003
www.accutherm.com.au

Brisbane (Distributor)

17 Medway Street
Rocklea QLD 4106
T: +61 7 3255 9255
F: +61 7 3255 9655
sales@gascomponents.com.au



MODELS G1.6 / G2.5 / G4 DIAPHRAGM METER

Performance Curves

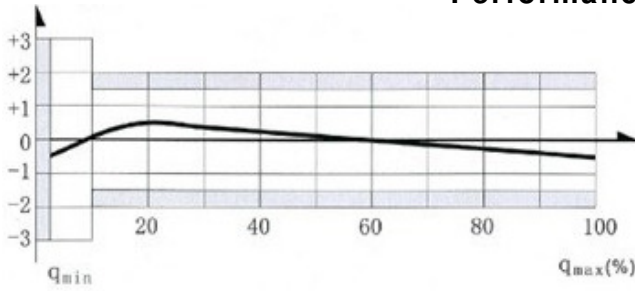

Accuracy (%)

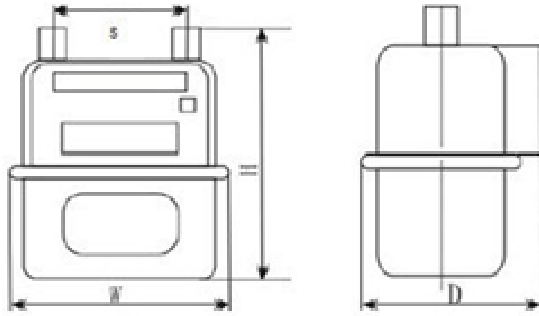

Technical Parameters

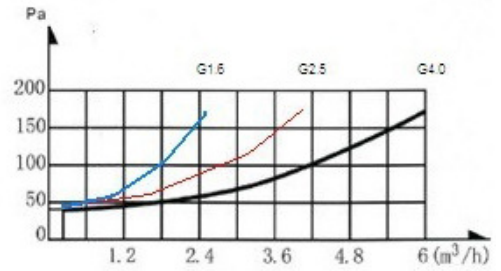

Pressure Loss

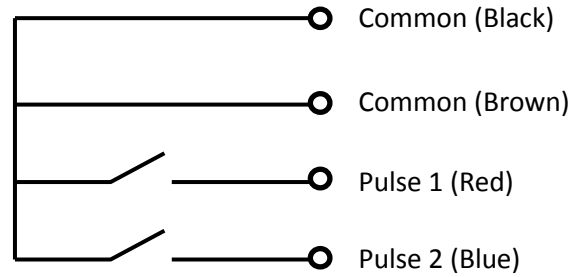

Wiring Diagram

In & Outlet Connections	S (mm)	W (mm)	D (mm)	H (mm)	Wt (kg)
M30 cap with 1/2" BSP Male tail	150	230	140	240	2.3

Specification	Unit	Data		
		G1.6	G2.5	G4
Nominal Flow Rate	m³/h	1.6	2.5	4.0
Max Flow Rate (Qmax)	m³/h	2.5	4.0	6.0
Min Flow Rate (Qmin)	m³/h	0.016	0.025	0.04
Max Work Pressure	kPa	50		
Max Allowable Pressure	kPa	75		
Total Pressure Loss	Pa	≤ 200		
Accuracy	Grade	B		
Basic Error	%	Qmin ≤ Q < 0.1 Qmax ± 3%		
		0.1 Qmax ≤ Q ≤ Qmax ± 1.5%		
Pulse Output		0.01m³/pulse (10 lt), < 30VDC		
Operating Ambient Temperature	°C	-10 to 60		
Connection Size		M30		
Accessories		Nut and Tail Set		

MODEL G6 DIAPHRAGM METER

Performance Curves

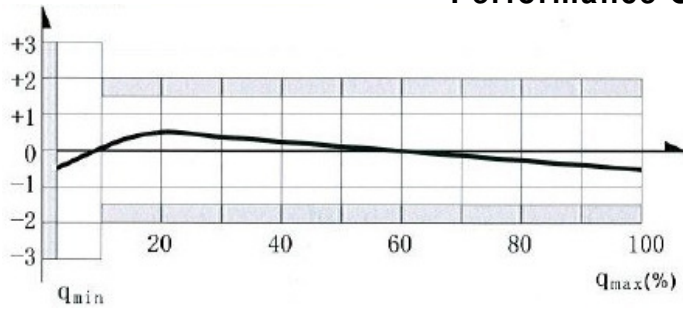

Accuracy (%)

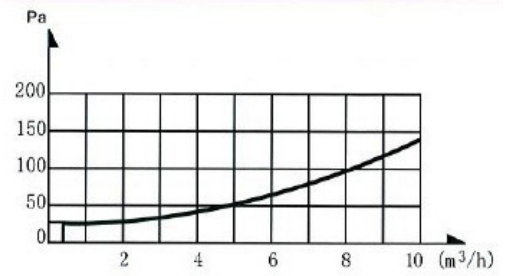

Pressure Loss

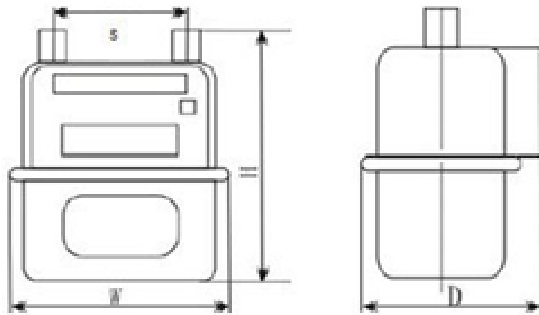

Technical Parameters

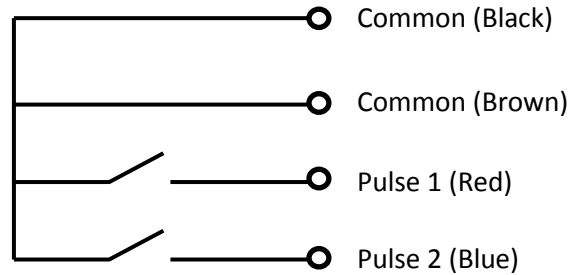

Wiring Diagram

In & Outlet Connections	S (mm)	W (mm)	D (mm)	H (mm)	Wt (kg)
1" BSPM	160	249	191	262	3.1

Specification	Unit	Data
Nominal Flow Rate	m ³ /h	6
Max Flow Rate (Qmax)	m ³ /h	10
Min Flow Rate (Qmin)	m ³ /h	0.06
Max Work Pressure	kPa	50
Max Allowable Pressure	kPa	75
Total Pressure Loss	Pa	≤ 200
Accuracy	Grade	B
Basic Error	%	Qmin ≤ Q < 0.1 Qmax ± 3%
		0.1 Qmax ≤ Q ≤ Qmax ± 1.5%
Pulse Output		0.01m ³ /pulse (10 lt), < 30VDC
Operating Ambient Temperature	°C	-10 to 60
Accessories		Nut and Tail Set

MODEL G10 DIAPHRAGM METER

Performance Curves

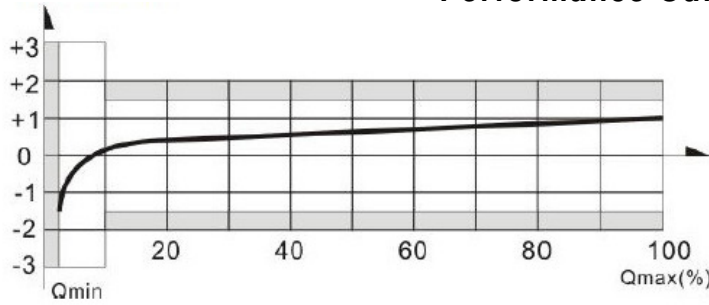

Accuracy (%)

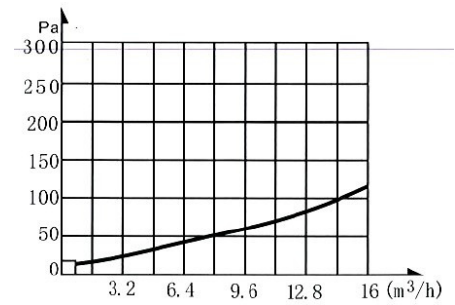

Pressure Loss

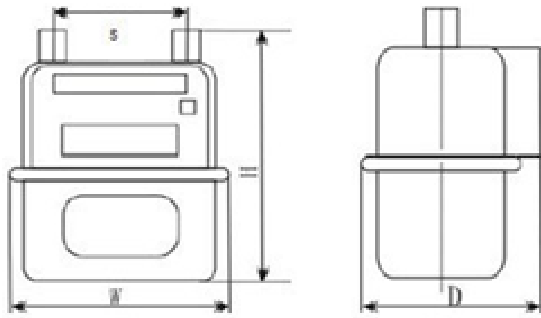

Technical Parameters

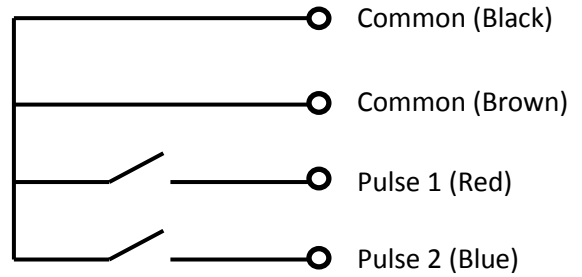

Wiring Diagram

In & Outlet Connections	S (mm)	W (mm)	D (mm)	H (mm)	Wt (kg)
1 1/2" BSPM	180	280	190	340	5.45

Specification	Unit	Data
Nominal Flow Rate	m ³ /h	10
Max Flow Rate (Qmax)	m ³ /h	16
Min Flow Rate (Qmin)	m ³ /h	0.1
Max Work Pressure	kPa	50
Max Allowable Pressure	kPa	75
Total Pressure Loss	Pa	≤ 200
Accuracy	Grade	B
Basic Error	%	Qmin ≤ Q < 0.1 Qmax ± 3%
		0.1 Qmax ≤ Q ≤ Qmax ± 1.5%
Pulse Output		0.1m ³ /pulse (100 lt), < 30VDC
Operating Ambient Temperature	°C	-10 to 60
Accessories		Nut and Tail Set

MODEL G16 DIAPHRAGM METER

Performance Curves

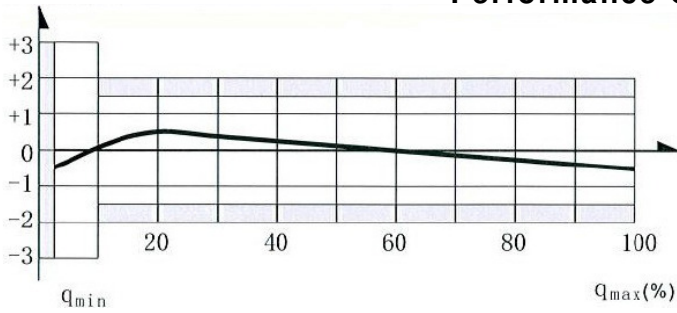

Accuracy (%)

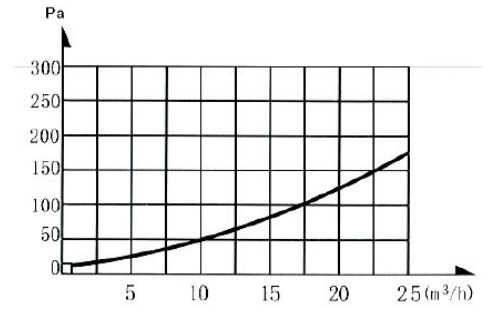

Pressure Loss

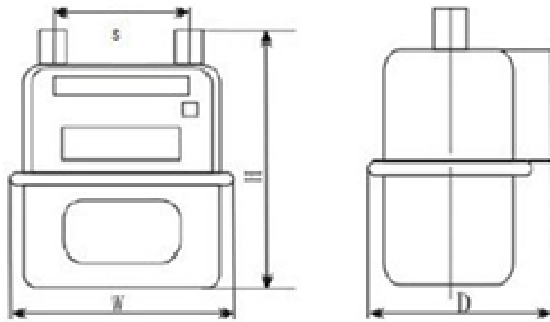

Technical Parameters

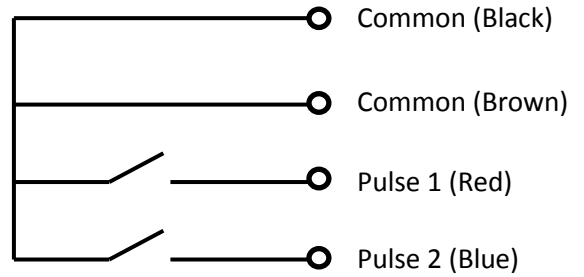

Wiring Diagram

In & Outlet Connections	S (mm)	W (mm)	D (mm)	H (mm)	Wt (kg)
1 1/2" BSPM	222	333	243	374	7.6

Specification	Unit	Data
Nominal Flow Rate	m^3/h	16
Max Flow Rate (Q_{max})	m^3/h	25
Min Flow Rate (Q_{min})	m^3/h	0.18
Max Work Pressure	kPa	50
Max Allowable Pressure	kPa	75
Total Pressure Loss	Pa	≤ 200
Accuracy	Grade	B
Basic Error	%	$Q_{min} \leq Q < 0.1 Q_{max} \pm 3\%$
		$0.1 Q_{max} \leq Q \leq Q_{max} \pm 1.5\%$
Pulse Output		$0.1 m^3/pulse$ (100 lt), $< 30VDC$
Operating Ambient Temperature	$^{\circ}C$	-10 to 60
Accessories		Nut and Tail Set

MODEL G25 DIAPHRAGM METER

Performance Curves

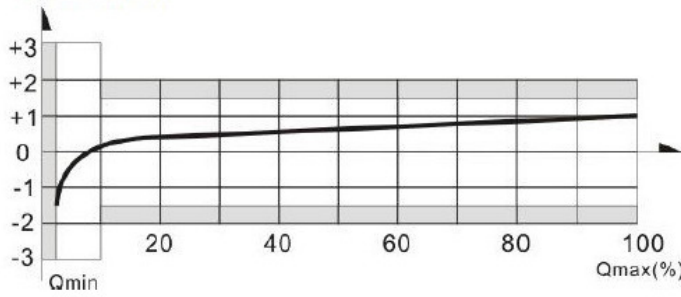

Accuracy (%)

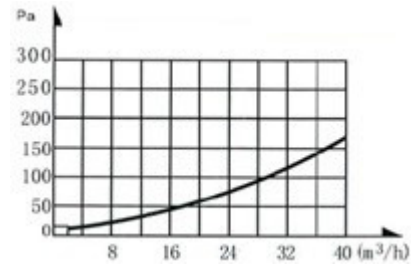

Pressure Loss

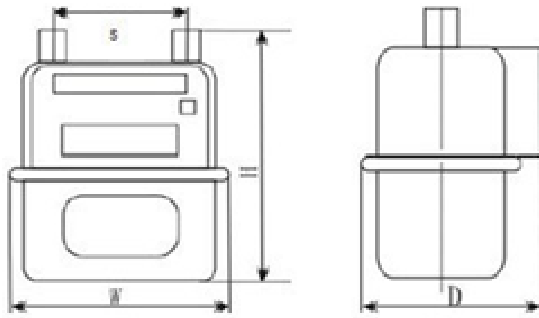

Technical Parameters

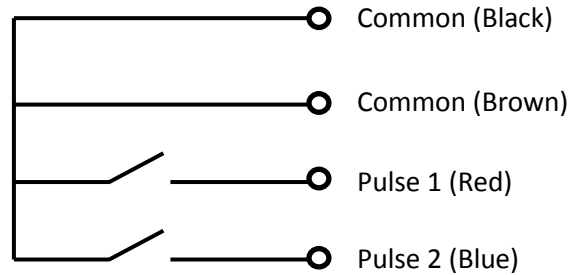

Wiring Diagram

In & Outlet Connections	S (mm)	W (mm)	D (mm)	H (mm)	Wt (kg)
2" BSPM	280	411	287	437.5	14

Specification	Unit	Data
Nominal Flow Rate	m ³ /h	25
Max Flow Rate (Qmax)	m ³ /h	40
Min Flow Rate (Qmin)	m ³ /h	0.25
Max Work Pressure	kPa	50
Max Allowable Pressure	kPa	75
Total Pressure Loss	Pa	≤ 200
Accuracy	Grade	B
Basic Error	%	Qmin ≤ Q < 0.1 Qmax ± 3%
		0.1 Qmax ≤ Q ≤ Qmax ± 1.5%
Pulse Output		0.1m ³ /pulse (100 lt), < 30VDC
Operating Ambient Temperature	°C	-10 to 60
Accessories		Nut and Tail Set

Disclaimer: www.accutherm.com.au/disclaimer.asp