



Norval
Pressure Regulators

Pressure Regulators

Norval

NORVAL pressure regulators are direct acting devices for low and medium pressure applications, controlled by a diaphragm and counter spring. These regulators are suitable for use with previously filtered, non corrosive gases and Bio Gas, depending upon its composition.

Modular Design

The modular design of the Norval pressure regulator allows the addition of a slam shut device for use as an “in line monitor” installed in the same body, without changing the face-to-face dimensions. Norval’s truly “top entry” design allows for easy maintenance without having to remove the body from the line. The features of the Norval regulator make it a suitable product for any application. The regulator can be mounted upside down. The fast response time makes it ideal for burner or industrial applications or whenever sudden changes of flowrate are part of the process. The balanced valve design offers very tight pressure control accuracy, even with inlet pressure changes, which makes the Norval a great choice for use in gas district systems, an application generally not suitable for direct acting regulators. The Norval’s nominal parts and easy maintenance keep operation costs down.

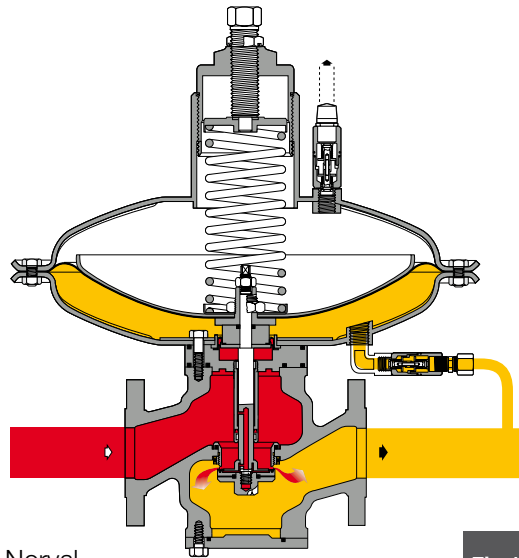

**DESIGNED
WITH YOUR
NEEDS IN MIND**

- COMPACT DESIGN
- EASY MAINTENANCE
- TOP ENTRY
- FAST RESPONSE TIME
- HIGH TURN-DOWN RATIO
- HIGH ACCURACY
- LOW OPERATION COSTS
- WIDE RANGE OF APPLICATIONS

SLAM SHUT
Norval

The slam shut is a safety device that immediately shuts off the gas when the downstream pressure exceeds the set point. The device can also be actuated manually.

SN Slam shut (see figure 2) can be incorporated on the standard regulator and on the in-line monitor.

The regulator with the incorporated slam-shut has Cg coefficients equal to 93% of the capacity of the basic regulator. A further advantage of the incorporated slam-shut valve is that it can be retrofitted at any time on a previously installed Norval (size up to 3" only) without modifying the regulating unit.

Main features of SN slam-shut device are:

- design pressure 232 PSIG (16 bar) for all components;
- accuracy (AG): up to $\pm 1\%$ of the pressure set-point for pressure increase; up to $\pm 5\%$ for pressure decreasing;
- internal bypass for resetting;
- intervention for over pressure and/or under pressure;
- optional manual push-button control;
- optional pneumatic or electromagnetic remote control;
- compact overall dimensions;
- easy maintenance;
- possibility of application of devices for remote signal (contact or inductive microswitches).

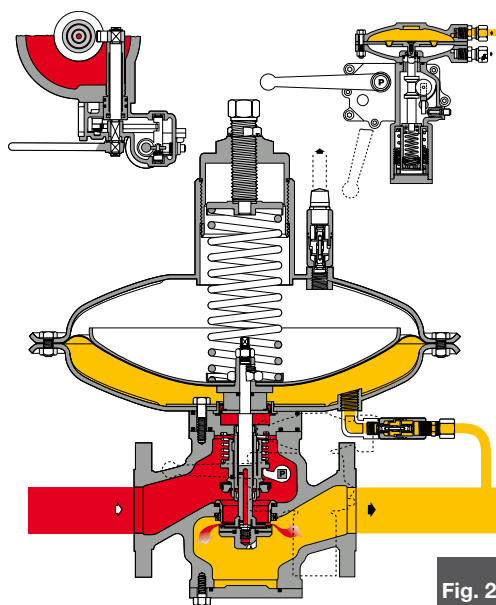
NORVAL + SLAM SHUT SN
Norval

Fig. 2

IN-LINE MONITOR

Norval

The monitor is an emergency regulator which comes into operation in case of main regulator failure. In the event of failure, the monitor regulator takes over control and allows the downstream pressure to reach the monitor set point.

Operation of the Norval functioning as Monitor

The NORVAL in-line monitor incorporates a balancing device (ER) which gives the regulator greater accuracy of regulated pressure and quick control intervention. It also stabilizes the monitor pressure so it does not interfere with the main regulators pressure control (see figure 3). This device can be retrofitted on a standard existing regulator.

MONITOR DEVICE ER

Norval

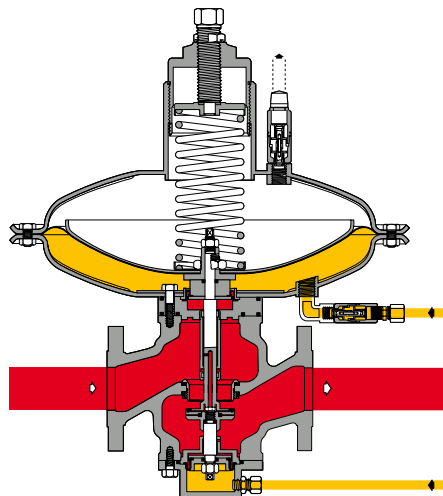

Fig. 3

MAIN FEATURES

Norval

- > Design pressure: up to 275 PSIG (19 bar)
- > Design temperature: -4 to + 140° F (-20° C to +60° C)
- > Ambient temperature: -4 to + 140° F (-20° C to +60° C)
- > Max inlet pressure P_{umax}: Size 1" to 3" 232 PSIG (16 bar) Size 4" to 8" 116 PSIG (8 bar)
- > Outlet pressure range of Wh: Size 1" to 4" 3" w.c. to 63.8 PSIG (8 to 4400 mbar)
Size 6" to 8" 5" w.c. to 26.1 PSIG (12 to 1800 mbar)
- > Accuracy class AC: up to 5
- > Closing pressure class SG: up to 10
- > Available size DN: 1", 1"1/2, 2", 2"1/2, 3", 4", 6", 8"
- > Flanging: class 150 RF according to ANSI B16.5 and PN16 according to ISO 7005.

MATERIALS
Norval

Body	Ductile iron GS 400-18 ISO 1083 for Size ≤ 6" Optional cast steel ASTM A216 WCB for all sizes
Head covers	Drop-forged carbon steel
Diaphragm	Rubberized canvas
Valve seat	Stainless steel
Seals	Nitrile rubber

The characteristics listed above refer to standard products. Special characteristics and materials for specific applications may be supplied upon request.

Coefficient
Norval

Nominal diameter (mm)	25	40	50	65	80	100	150	200
Size (inches)	1"	1 1/2"	2"	2 1/2"	3"	4"	6"	8"
C_g coefficient	331	848	1,360	2,240	3,395	5,100	10,600	16,600
K_G coefficient	348	892	1,430	2,356	3,571	5,365	11,151	17,463
C₁ coefficient	106.78	106.78	106.78	106.78	106.78	106.78	106.78	106.78

For sizing formula refer to www.fiorentini.com/sizing

CAUTION:

The graph gives a quick reference of maximum recommended regulator capacity depending on selected size. Values are expressed in actual m³/h of Natural gas (s.g. 0.6): to have the data directly in Nm³/h it is necessary to multiply the value by the outlet pressure value in bar – absolute.

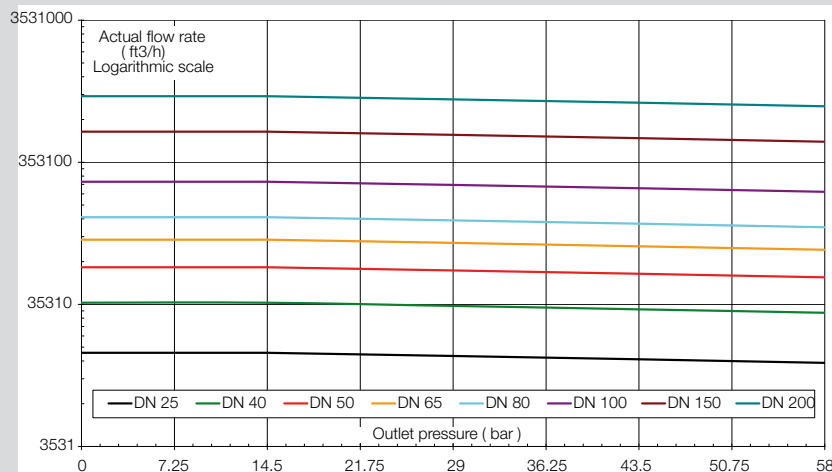

Control heads

Norval

Outlet pressure range is determined by the control head installed. The table below shows the proper head to choose for each size of regulator. The ranges of outlet pressure are in inches w.c. & PSIG.

Size (Inches)	1"	1 1/2"	2"	2 1/2"	3"	4"	6"	8"
mm	25	40	50	65	80	100	150	200
ø 817							5"w.c. - 1.1	5"w.c. - 1.1
ø 658							1.1 - 5.9	1.1 - 5.9
ø 630				4"w.c.-1.2	6"w.c. - 1.2	6"w.c. -1.2	3.2 - 9.4	3.2 - 9.4
ø 495	6"w.c. - 1.2	6"w.c. - 1.2	6"w.c. - 1.2	1.2 - 7.7	1.2 - 7.7	1.2 - 7.7	5.9 - 26.1	5.9 - 26.1
ø 375	1.2 - 16	1.2 - 16	1.2 - 16	6.8 - 40.6	6.8 - 40.6	6.8 - 40.6		
ø 375TR	13.3 - 63.8	13.3 - 63.8	13.3 - 63.8	13.3 - 63.8	13.3 - 63.8	13.3 - 63.8		

Slam-shut pressure switches

Norval

Pressure switch	SN 91	SN 92
Set point range for Overpressure (OPSO)	10" w.c - 17.4	29" w.c. - 80
Set point range for Underpressure (UPSO)	1/4" - 3.5	10" w.c - 39

Working pressure in w.c. and PSIG

INSTALLATION EXAMPLE

Norval

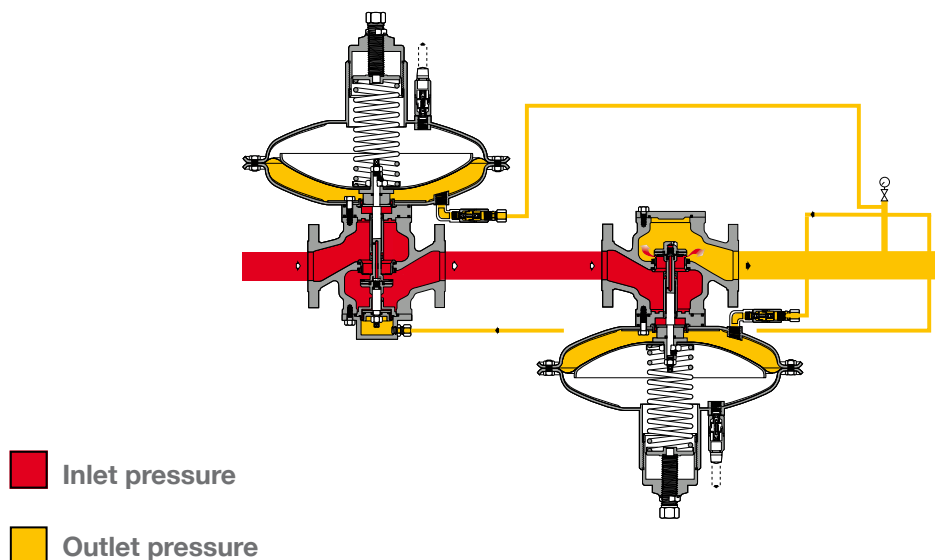

* Refer to specific spring table for regulators installed upside down

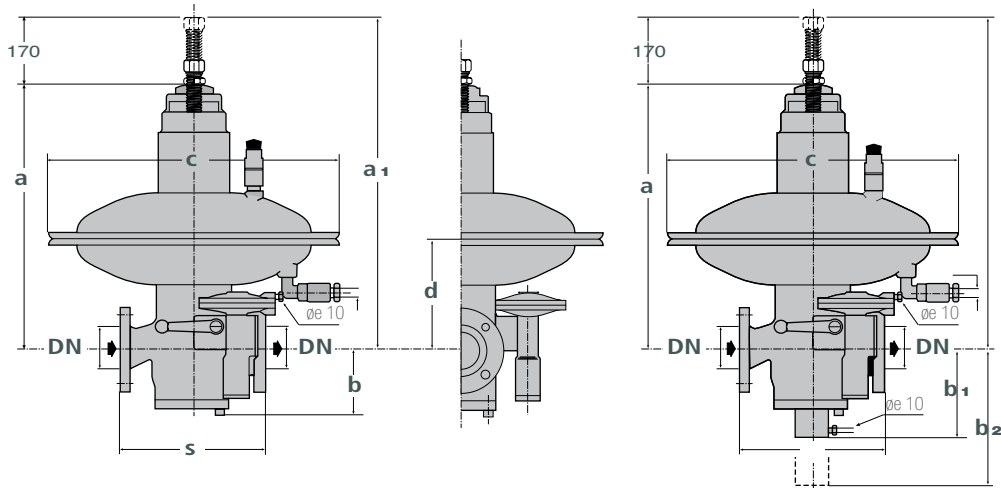
DIMENSIONS
Norval

Overall dimensions in Inches
Norval

Size Inches	c				ø 817			ø 658			ø 630			ø 495			ø 375			ø 375TR			
	s*	b	b1	b2	a	a1	d	a	a1	d	a	a1	d	a	a1	d	a	a1	d	a	a1	d	
1"	7.25	3.94	7.87	9.84										18.11	24.80	6.89	16.73	23.43	6.10	16.73	23.43	6.10	
1 1/2"	8.75	4.72	8.66	10.63										18.70	25.39	7.48	17.52	24.21	6.69	17.52	24.21	6.69	
2"	10	4.72	8.66	10.63										18.70	25.39	7.48	17.52	24.21	6.69	17.52	24.21	6.69	
2 1/2"	10.88	9.45	9.45	11.42							21.26	27.95	8.66	19.69	26.38	8.27	17.91	24.61	7.48	18.31	25	7.68	
3"	11.75	9.45	9.45	11.42							21.26	27.95	8.66	19.69	26.38	8.27	17.91	24.61	7.48	18.31	25	7.68	
4"	13.88	11.02	11.02	12.99							25.20	31.89	12.20	23.62	30.31	11.81	21.85	28.54	10.83	22.24	28.94	11.02	
6"	17.75	8.66	12.60	14.57	29.92	36.61	15.75	28.35	35.04	14.96	26.57	33.27	14.96	26.38	33.07	14.76							
8"	21.38	10.24	14.17	16.14	33.86	40.55	19.69	32.28	38.98	18.90	30.51	33.27	18.90	30.31	37.01	18.70							

Weights in pounds
Norval

Size (Inches)	1"	1 1/2"	2"	2 1/2"	3"	4"	6"	8"
Size (mm)	25	40	50	65	80	100	150	200
Norval	93	106	110	170	203	267	454	642
Norval with slam-shut/SN	104	117	121	181	214	278	465	653
Norval with monitor	106	121	128	187	220	284	476	666
Norval with slam-shut/SN and monitor	117	132	139	198	231	295	487	677

The Norval regulator conforms to ISA 4.1 standard

Face to face dimensions S according to IEC 534-3 and EN 334



Governors



Dival 500



Pressure Regulators



**Pietro
Fiorentini**

Fiorentini USA
4555 South Berkeley Lake Road
Norcross, GA 30071

Toll - Free: 888.618.8787
Fax: 770.448.7312

www.fioussa.com

Pietro Fiorentini S.p.A.
via E.Fermi 8/10
I-36057 Arcugnano (VI) Italy

Tel: +39 0444 968.511
Fax: +39 0444 960.468

www.fiorentini.com

This data is not binding. We reserve the right to make changes without prior notice.