

## RIELLO 40 N SERIES

The Riello 40 N series of one stage heavy oil burners, is a complete range of products developed to respond to any request for the use of heavy oil in heating systems and light industrial processes. The Riello 40 N series is available in two different models, with an output ranging from 34 to 217 kW, divided into two basic structures.

All the models use many components designed by Riello for the Riello 40 series but are fitted with special components for heavy oil combustion.

The high quality level guarantees safe working.

In developing these burners, special attention has been paid to reducing noise, to the ease of installation and adjustment, to reducing the size in order to facilitate installation in any kind of boiler on the market.

All the models are conform to EMC European Directives, for Low Voltage and Machinery.

All the Riello 40 N burners are tested before leaving the factory.



N 10	34 ÷ 102 kW
N 20	102 ÷ 217 kW

### FIRING RATES

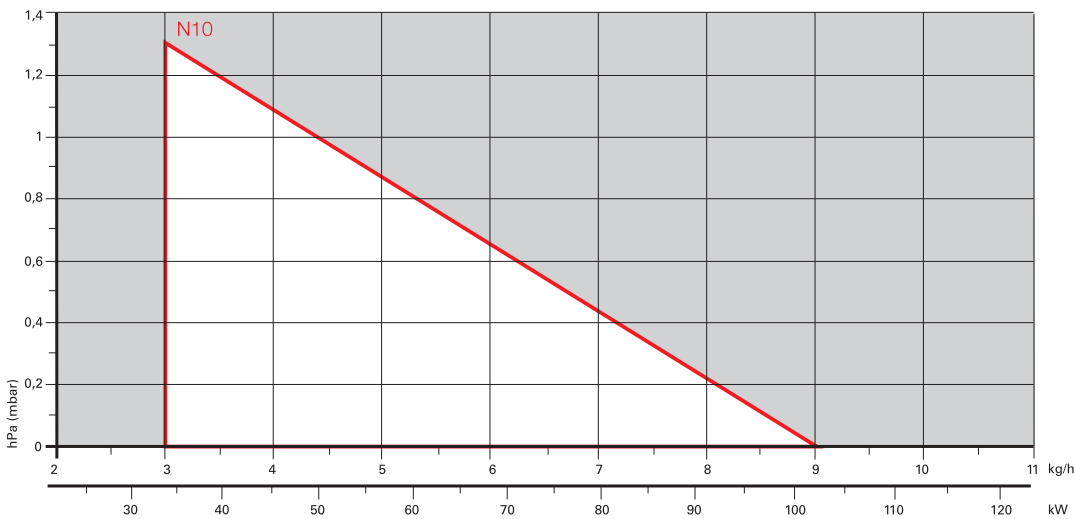

Useful working field for choosing the burner

Test conditions  
 Temperature: 20°C  
 Pressure: 1013,5 mbar  
 Altitude: 0 m a.s.l.

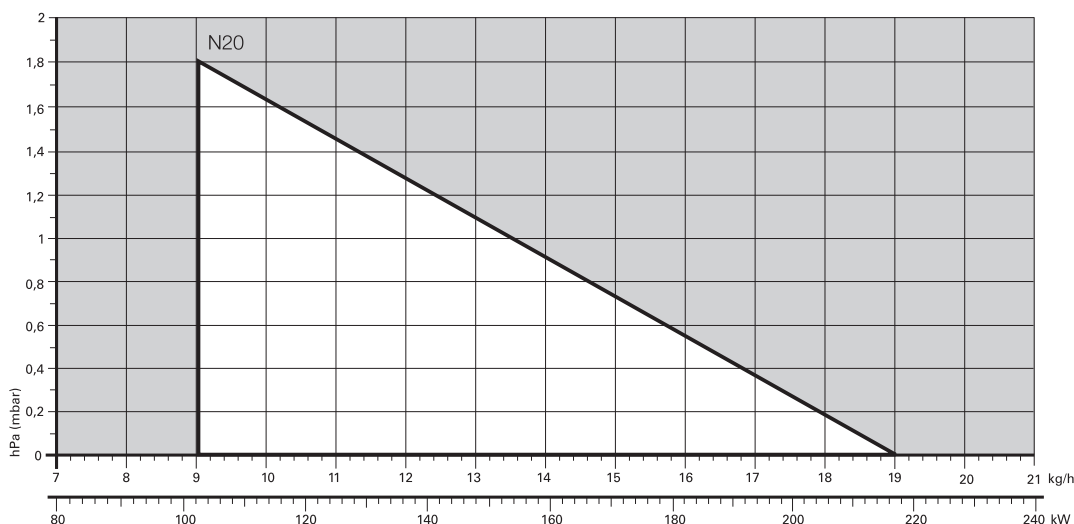

# One Stage Heavy Oil Burners

## RIELLO 40 N SERIES

### Overall dimensions (mm)

#### BURNER

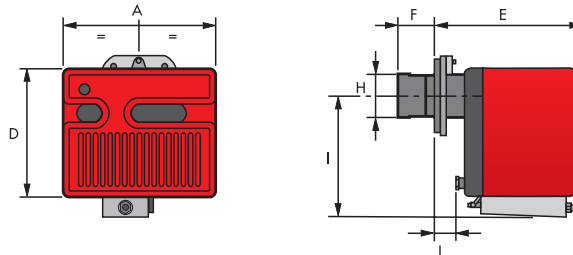

MODEL	A	D	E	F	H	I	L
► N10	305	262	275	108	105	258	25
► N20	350	298	295	118	125	280	35

#### BURNER - BOILER MOUNTING FLANGE

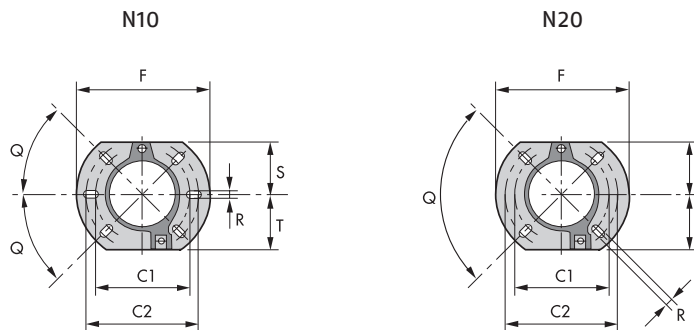

MODEL	C1	C2	F	Q	R	S	T
► N10	140	170	189	45°	11	83	83
► N20	160	190	213	90°	11	99	99

#### PACKAGING

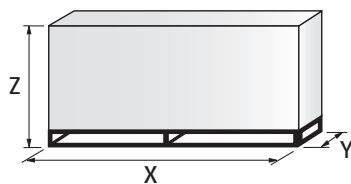

MODEL	X	Y	Z	kg
► N10	395	307	375	26
► N20	425	352	410	29

## RIELLO 40 N SERIES

## Specification

### DESIGNATION OF SERIES

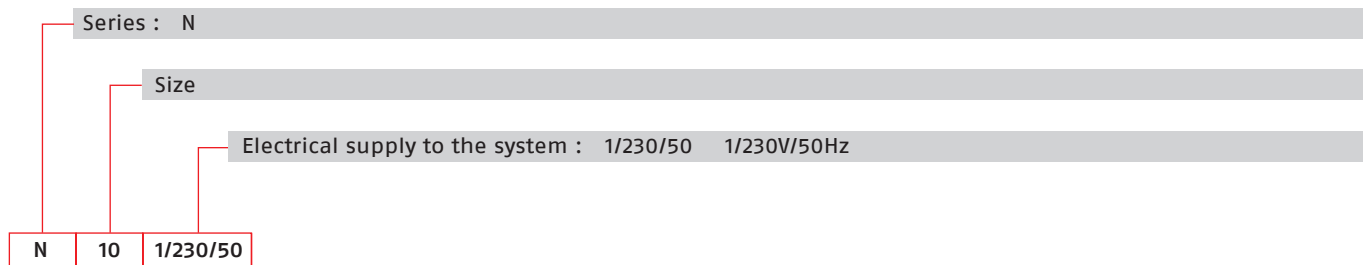

### STATE OF SUPPLY

Completely automatic monobloc heavy oil burners, one stage operation, made up to:

- Fan with forward curve blades
- Metallic cover lined with sound-proofing material
- Metallic air damper
- Single phase electric motor 230 V, 50 Hz
- Combustion head fitted with:
  - stainless steel head cone, resistant to high temperatures
  - ignition electrodes
  - flame stability disk
- Geared pump for fuel supply, fitted with:
  - filter
  - pressure regulator
  - attachments for fitting a pressure gauge and vacuum meter
  - internal by-pass for preparing for single-pipe installations
- Heavy oil preheater
- Heavy oil filter into the preheater
- Heavy oil manometer
- Heavy oil thermometer
- Heavy oil protection valve
- Heavy oil outlet valve
- Adjustment thermostat with probe
- Thermostat for fuel low temperature
- Fuel feed solenoid valve incorporated in the pump
- Terminal block for electrical links
- Photocell for flame detection
- Electronic flame control equipment
- Electronic transformer
- Protective filter against radio interference
- IP X0D (IP 40) protection level.

#### Standard equipment:

- Heavy oil nozzle
- Two flexible pipes with seal for connection to the heavy oil supply line
- Two nipples for connection to the pump
- Flange, screws and nuts for fixing
- Thermal gasket
- Hinge kit
- Grommet
- Instruction handbook for installation, use and maintenance
- Spare parts catalogue.

# One Stage Heavy Oil Burners

## RIELLO 40 N SERIES

### Available models

CODE	MODEL		HEAT OUTPUT		TOTAL ELECTRICAL POWER (kW)	CERTIFICATION	NOTE
			(kW)	(kg/h)			
3412016	N10	1/230/50	34 - 102	3 - 9	1,1	-	(1)
3412816	N20	1/230/50	102 - 217	9 - 19	1,8	-	(1)

Net calorific value: 11,3 kWh/kg; 9720 kcal/kg - Max Viscosity at 50°C: 5°E (38 mm<sup>2</sup>/s, cSt), Type MEDIUM HEAVY OIL / USA n° 4.  
(1) Austrian version.

### Burner accessories

#### Cartridge filter



BURNER	KIT CODE
► N10 - N20	3004588

#### Self-cleaning filter



BURNER	KIT CODE
► N10 - N20	3000861